

# Boiler Switch

Model No. JSJSLW920

## Instruction Manual

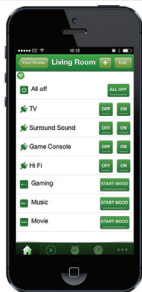

Professional Series

[www.lightwaverf.house](http://www.lightwaverf.house)

Version 2

# EC DECLARATION OF CONFORMITY

Responsible Authority:

LightwaveRF PLC,  
Innovation Campus Birmingham  
Faraday Wharf  
Holt Street  
Birmingham  
B7 4BB

Tel: +44 (0)121 250 3625  
Email: enquiries@lightwaverf.com

Model Number(s):  
Description:  
Directives this equipment  
Complies with:

JSJSLW920  
Boiler Switch  
2006/95/EC The Low Voltage Directive N/A  
2004/108/EEC The Electromagnetic Compatibility Directive  
1999/5/EC R&TTE Directive  
93/68/EEC CE Marking Directive

Standards Applied in order to verify compliance

Safety: BS EN 60730-1: 2011

Health:

R&TTE: EN 301 489-1 V1.9.2: (2011-09), EN 301 489-3 V1.4.1: (2002-08)  
EN 300 220-1 V2.1.1: 2006, EN 300 220-2 V2.1.2: 2007  
EMC: EN 301 489-1 V1.9.2: (2011-09), EN 301 489-3 V1.4.1: (2002-08),  
EN 55022: 2010, EN 61000-3-2: 2006 +A1: 2009 +A2: 2009 Class A,  
EN 61000-3-3: 2008, EN61000-4-2: 2009,  
EN 61000-4-3: 2006 +A1: 2008 +A2: 2010, EN 61000-4-4: 2012,  
EN 61000-4-5: 2006, EN 61000-4-6: 2009, EN 61000-4-11: 2004

For and on behalf of LightwaveRF PLC

-----  
Name            J Shermer  
Position        Managing Director



## How do I get started?

To install the Boiler Switch, please follow these instructions. You must also refer to the wiring instructions specific to your boiler type which can be downloaded from [www.lightwaverf.com/product-manuals](http://www.lightwaverf.com/product-manuals). The setup section will then explain how to link the Boiler Switch to the LightwaveRF Home Thermostat.



## What do I need?

To install the Boiler Switch, you must understand how to safely turn off the electricity supply and be comfortable with following some basic wiring instructions. You will also need suitable electrical screwdrivers.



## Help video & further guidance

For additional guidance, and to watch a video that will help guide you through the installation process, please visit the support section on [www.lightwaverf.house](http://www.lightwaverf.house)





## Overview

### Front view

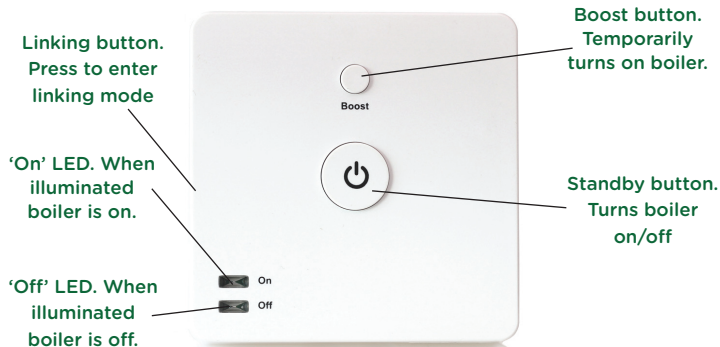

**IMPORTANT:** All LightwaveRF products can be legally DIY installed in your own home; however, if in doubt, always consult a qualified electrician or heating engineer. It is important to install this product in accordance with the following instructions. Failure to do so may void your warranty.



## Rear view with backplate removed

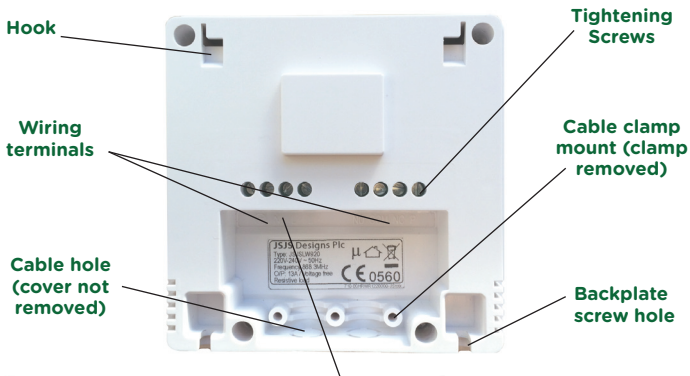

**IMPORTANT:** If conducting an insulation resistance test, all LightwaveRF products **must** be disconnected from the mains, or damage will occur.



## Installation preparation

### Key installation tools and materials



Cross-head  
screwdriver



Flat-head  
screwdriver



Wire-cutters

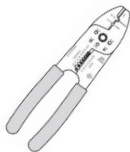

Wire-strippers



Torch



Sharp Knife



Electrical tape

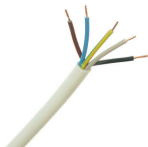

5 core cable

**IMPORTANT:** If you are unsure about how to use any of these tools and materials, or any stage of the installation process, always consult a qualified electrician or heating engineer.



## Safety precautions

- Prior to installing the Boiler Switch, read through the wiring instructions provided thoroughly. Make sure that you understand your heating setup as specified on the following pages.
- Before proceeding with the installation, check and ensure that the boiler is **OFF** and that no mains power is being received. Remember - the mains terminals remain live even if the boiler's on/off controls are switched off. If a separate wiring centre needs to be accessed, make sure that no power is being received. If in doubt always consult a qualified electrician.
- Ensure that the Boiler is earthed.
- Never take unnecessary risks if unsure, as damage can be caused by an incorrect installation.
- Do not strip the outer sheathing of flexible cables more than necessary to prevent short circuits.
- Ensure that all cords pass through the cable clamps in the rear of the control box and are securely fixed. Ensure that the power supply is connected such that the current carrying conductors become taut before the earth conductor should the supply cord slip from the cable clamp.



# Installation

## Remove the backplate and cable clamp

To gain access to the wiring terminals on the Boiler Switch, you must first remove the backplate. This can be done by loosening the two screws sited at the base of the unit using a suitable screwdriver. Once the screws are loosened enough so that they protrude from their screw holes, gently lift the backplate away from the main unit and slide it down. Once the hooks are free from their mountings, the backplate should slide free.

Once the backplate has been removed, the cable clamp needs to be unscrewed ready to accommodate the wires. There are also two capped holes situated at the base of the unit. One of these (or two depending on the number of cables used) needs to have its cap removed using a suitable blade so that the wires can pass through.

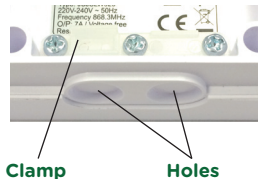





## Understanding your heating setup

To know where to install the Boiler Switch, you will need to know the type of heating setup that you have at home. Please identify your system and then refer to the corresponding section after this page.

**1. Combi boiler (most common)** - In the vast majority of cases, your domestic boiler will be a standard 'combi'. It provides both hot water and water for central heating directly. It may have an accompanying 'room thermostat' which is usually located in the hall.

**2. Y plan system** - this consists of a 'system' boiler which supplies both a hot water tank and the central heating. There is a single motorised valve which distributes heated water to either the hot water tank, the heating or both. It will usually include a room thermostat.

**3. S plan system** - this also consists of a system boiler supplying both a hot water tank and the central heating. In this case there are two motorised valves, one regulating the supply for the hot water and one for the heating. It will usually include a room thermostat.

**4. Multi-zone system (S plan plus)** - this is similar to the S plan system, but has multiple motorised valves controlling supply to different heating areas or 'zones'.



# Install 1: combi boiler

## 1. Wiring to a standard combi setup (typical)

The setup shown below is a standard combi system which is common to most homes. Combi systems may or may not include a 'room thermostat' such as the one pictured. This is wired into the room thermostat terminal. Even if there is no existing room thermostat, a combi boiler will always include a room thermostat (RT) terminal into which a thermostat can be wired. This is where the LightwaveRF Boiler Switch should be connected (see next page).



The thermostat is wired into the 'room thermostat' (RT) terminal in boiler (standard terminal in all combi boilers)



## Standard combi setup with LightwaveRF Boiler Switch

The Boiler Switch replaces the original thermostat and is wired into the same room thermostat (RT) terminal. Unlike the original thermostat, however, it should now be located near the boiler, as it also needs to take incoming mains power from terminals located next to the room thermostat terminal.

**The Boiler Switch is connected to the room thermostat terminal in the boiler. It also takes live mains from the boiler.**

**The wireless LightwaveRF Home Thermostat replaces the existing one and controls the boiler via the Boiler Switch**

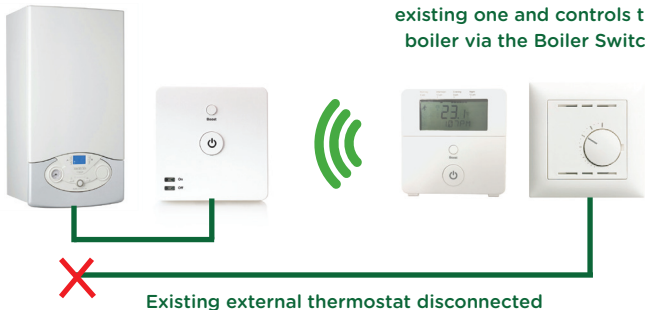



## Install 1: combi boiler

### Download your boiler manual from the support menu

Standard combi boilers should all include the necessary connection points needed to wire the LightwaveRF Boiler Switch. However, these may be located differently depending on the manufacturer. Please now locate and refer to the specific boiler manual for your make and model of boiler. This can be downloaded from [www.lightwaverf.com/product-manuals](http://www.lightwaverf.com/product-manuals).



Please continue to follow the general instructions provided here, whilst referring to your boiler manual to find the exact location of the appropriate terminals described. You should, most importantly, refer to the main boiler wiring diagram for circuit wiring information. If you have a Y plan, and S plan or a multi-zone system that utilises a wiring centre, then you will need to refer to the generic wiring diagrams in this manual for guidance. If you are unsure about your wiring configuration, consult an electrician or heating engineer.



## Access the boiler wiring centre

The Boiler Switch needs to be wired to the room thermostat (RT) connection. In order to locate this, you must gain access to the boiler wiring centre inside the boiler. You should refer to your specific boiler manual to find out how to do this. Make sure that you **turn off the mains power** to the boiler.

In a standard combi, the wiring centre is usually located behind the front cover. The example shown below represents a common Vaillant combi boiler.

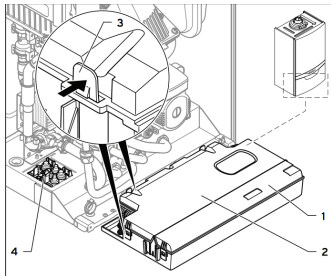
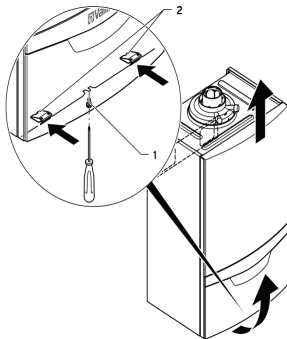





## Locate mains power terminals

The Boiler Switch also needs to take mains power from the boiler. This can be routed from live, neutral and earth terminals located in the wiring centre. You should refer to your boiler manual to locate them.

The terminals are usually located next to or near to the 'room thermostat' connection. The picture on the right shows the arrangement of the mains (marked L & N) and room thermostat terminals (marked 3 & 4 shown by the loop of wire) on a typical Vaillant combi

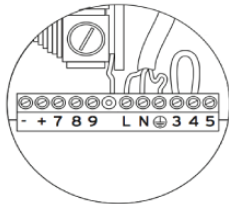

## Prepare the cables

The simplest way to connect the Boiler Switch to the boiler is to use a single 5 core cable; however, a 2 core cable can be used to connect to the room thermostat terminals and a separate 3 core to the power terminals if necessary. This may be more appropriate if the terminals are further apart. Ensure that there is enough cable to reach from the boiler to the Boiler Switch when wall mounted.

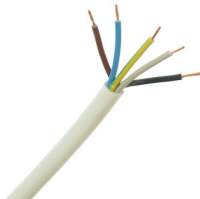



# Install 1: combi boiler

## Wire the Boiler Switch

Link the Boiler Switch and boiler terminals as shown in the diagram using the single 5 core cable. Remember that the terminal arrangement on your boiler may differ, so please refer to your specific boiler manual for guidance.

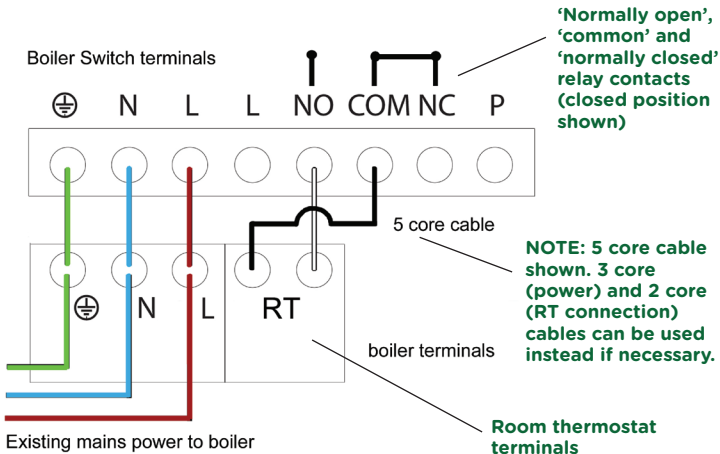





## 2. Wiring to a Y plan heating system

The basic diagram below shows the main constituent elements of a Y plan system which is common in larger houses. The system boiler produces hot water which is stored in the tank and/or circulated in the central heating system. A motorised valve allows flow to the tank, the radiators or both together. A room thermostat controls the flow to the heating by opening or closing the valve. This thermostat needs to be disconnected at the wiring centre and replaced by the Boiler Switch.

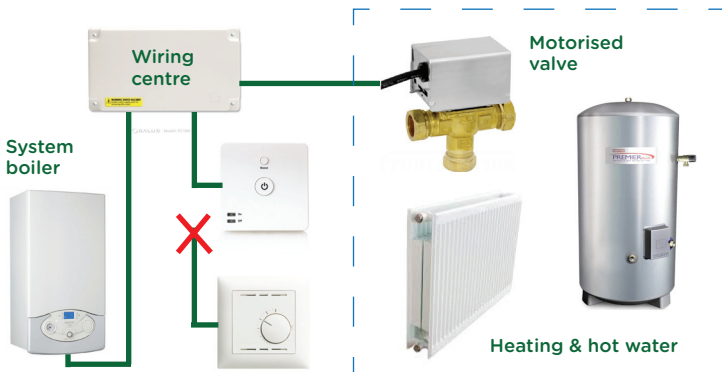



## Install 2: Y plan

### Access the wiring centre

The Boiler Switch needs to be wired in place of the existing room thermostat. In order to locate this connection, you must gain access to the system wiring centre. This is often located near to the hot water cylinder. Make sure that you **turn off the mains power**. The connections in the wiring centre for a Y plan setup are usually to a standard format. A typical example (Honeywell system) is shown in the diagram on the next page.

### Locate the room thermostat terminals

Once you have accessed the wiring centre, you need to locate the room thermostat's connecting wires, and terminals that they are connected to. There should be two main switching wires (usually white and black). In some cases there will also be a neutral connection (usually blue). Make a note of the locations before disconnecting the wires, as they may not be marked.

### Locate mains power terminals

The Boiler Switch also needs to take mains power. This can be routed from live, neutral and earth terminals located in the wiring centre (see the example in the diagram). The terminals are usually located next to or near to the room thermostat connections. Take extreme care when dealing with live mains; if unsure always consult an electrician as an incorrect install could result in damage being caused.



## Typical wiring for a Y plan setup

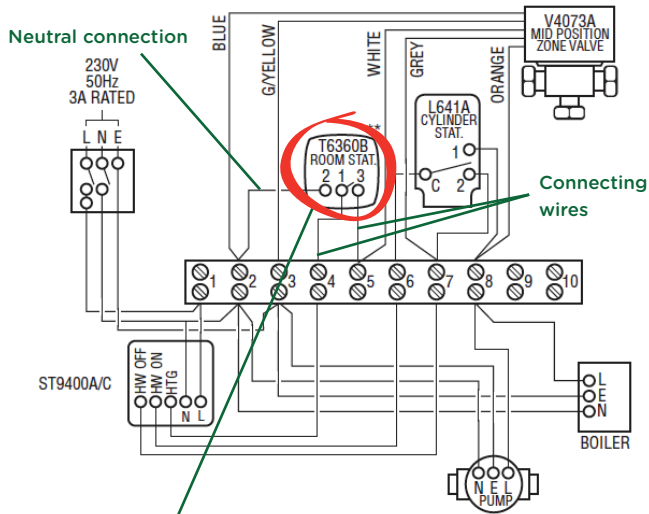

Room thermostat (with neutral wire connection) to be replaced by Boiler Switch which requires additional live and earth connections.



## Install 2: Y plan

### Wire the Boiler Switch

Use a 5 core cable to connect the Boiler Switch to the wiring centre (you can also use a 2 core and a 3 core cable together instead). Connect the room thermostat terminals, and add live, neutral and earth as shown in the diagram. Remember that the terminal arrangement in your wiring centre may not be identical; this is an approximate guide only.

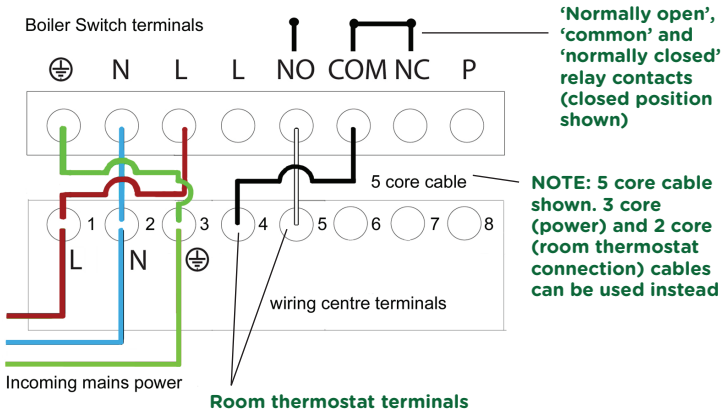



### 3. Wiring to an S-plan heating system

The basic diagram below shows the main constituent elements of an S plan system which is common in larger houses. The system boiler produces hot water which is stored in the tank and/or circulated in the central heating system. Two motorised valves allow flow to the tank, the radiators or both together. A room thermostat controls the flow to the heating by opening or closing the heating valve. This thermostat needs to be disconnected at the wiring centre and replaced by the Boiler Switch.





## Install 3: S plan

### Access the wiring centre

The Boiler Switch needs to be wired in place of the existing room thermostat. In order to locate this connection, you must gain access to the system wiring centre. This is often located near to the hot water cylinder. Make sure that you **turn off the mains power**. The connections in the wiring centre for an S plan setup are usually to a standard format. A typical example (Honeywell system) is shown in the diagram on the next page.

### Locate the room thermostat (RT) terminals

Once you have accessed the wiring centre, you need to locate the room thermostat's wire connections, and terminals that they are connected to. There should be two main switching wires (usually white and black). In some cases there will also be a neutral connection (usually blue). Make a note of the locations before disconnecting the wires, as they may not be marked.

### Locate mains power terminals

The Boiler Switch also needs to take mains power. This can be routed from live, neutral and earth terminals located in the wiring centre. The terminals are usually located next to or near to the room thermostat connections. Take extreme care when dealing with live mains; if unsure always consult an electrician as an incorrect install could result in damage being caused.



## Typical wiring for an S plan setup

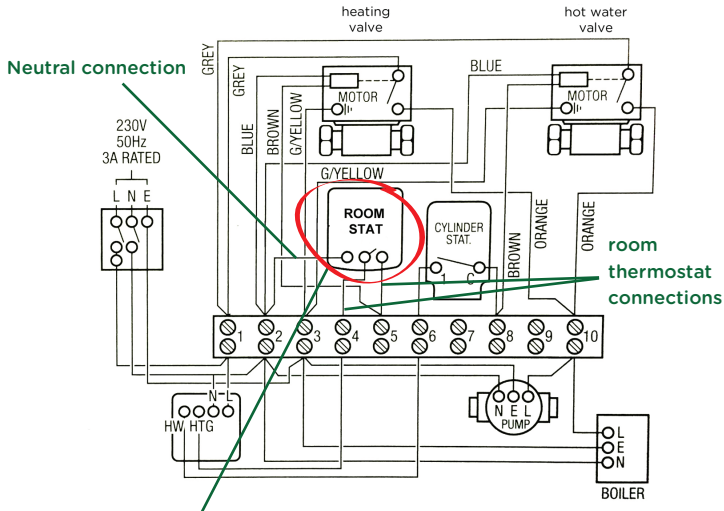

Room thermostat (with neutral wire connection) to be replaced by Boiler Switch which requires additional live and earth connections.



## Install 3: S plan

### Wire the Boiler Switch

Use a 5 core cable to connect the Boiler Switch to the wiring centre (you can also use a 2 core and a 3 core cable together instead). Connect the room thermostat terminals, and add live, neutral and earth as shown in the diagram. Remember that the terminal arrangement in your wiring centre may not be identical; this is an approximate guide only.

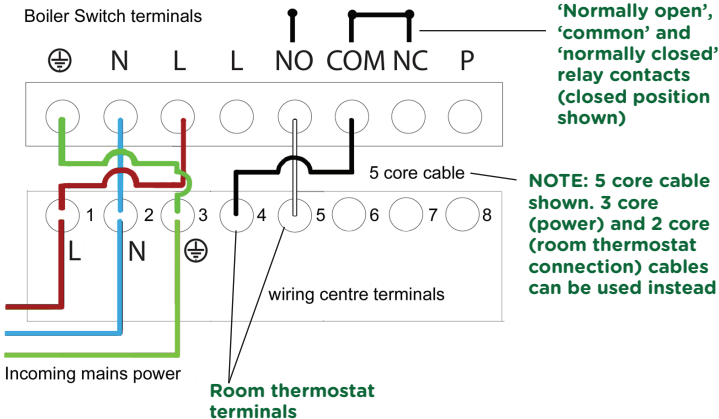





## 4. Wiring to a multi-zone heating system

The basic diagram below shows the main constituent elements of a multi-zone (S plan plus) system. This system resembles the S plan system (see previous section), but includes multiple motorised valves each controlling a heating zone. A separate thermostat controls each zone valve. Each one needs to be disconnected at the wiring centre and replaced by a Boiler Switch.

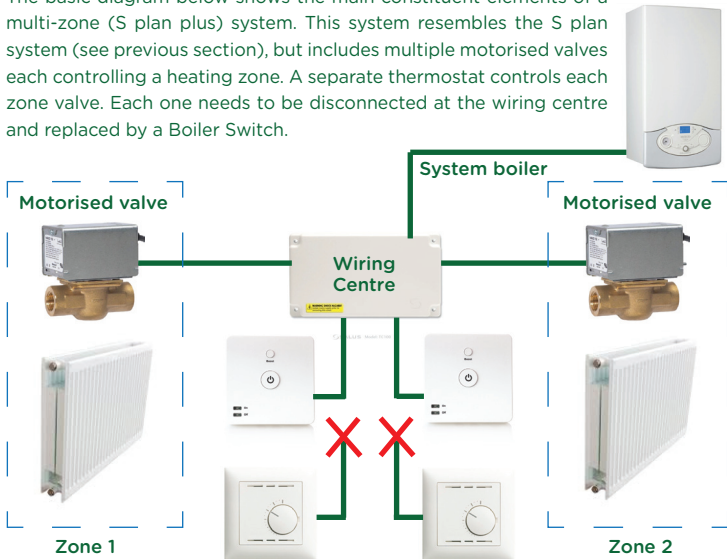



## Install 4: Multi-zone (S plan plus)

### Access the wiring centre

A Boiler Switch needs to be wired in place of each existing room thermostat. In order to locate these connections, you must gain access to the system wiring centre. This is often located near to the hot water cylinder. Make sure that you **turn off the mains power**. The connections in the wiring centre for an S plan plus setup are usually to a standard format. A typical example (Honeywell system) is shown in the diagram on the next page.

### Locate the terminals for each room thermostat (RT)

Once you have accessed the wiring centre, you need to locate each room thermostat's connecting wires, and terminals that they are connected to. There will be a connected thermostat for each zone valve present, each with two main switching connections (usually white and black). In some cases, a thermostat may also have a neutral connection (usually blue). Make a note of the locations before disconnecting the wires, as they may not be marked.

### Locate mains power terminals

Each Boiler Switch also needs to take mains power. This can be routed from live, neutral and earth terminals located in the wiring centre (see the example in the diagram). Take extreme care when dealing with live mains; if unsure always consult an electrician as an incorrect install could result in damage being caused.

# Install 4: Multi-zone (S plan plus)



## Typical wiring for a multi-zone (S plan plus) setup

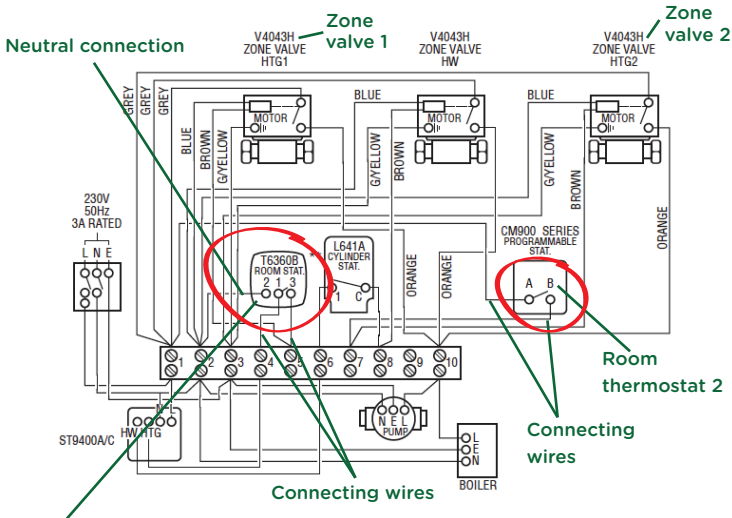

Room thermostat 1 (with neutral wire connection) to be replaced by Boiler Switch which requires additional live and earth connections.



# Install 4: Multi-zone (S plan plus)

## Wire the Boiler Switch

Use 5 core cables to connect each Boiler Switch to the wiring centre (you can also use two 2 core and two 3 core cables instead). Connect the room thermostat terminals, and add live, neutral and earth as shown in the diagram. Remember that the terminal arrangement in your wiring centre may not be identical; this is an approximate guide only.

Boiler Switch 1 terminals

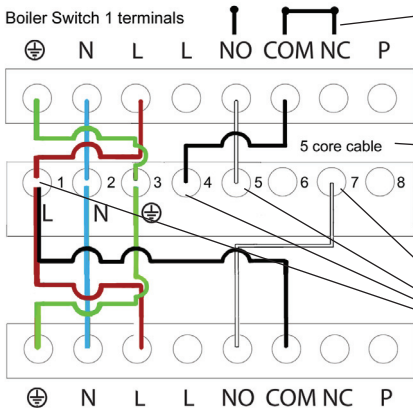

**'Normally open', 'common' and 'normally closed' relay contacts (closed position shown)**

**NOTE: 5 core cable shown. 3 core (power) and 2 core (room thermostat connection) cables can be used instead**

**Room thermostat connections**

Boiler Switch 2 terminals



## Completing the Install

### Install the cable clamp

Once the cable(s) have been connected, the cable clamp needs to be reattached in order to secure them and to ensure that they cannot become dislodged from the terminal connections. The cable(s) should run through holes situated at the base of the unit.



Clamp

Holes

### Mounting the Boiler Switch

You can now close the boiler casing by following the relevant instructions from your manual. It is recommended to mount the Boiler Switch to the wall next to the boiler in a suitable place. The backplate includes two screw holes which allow the plate to be mounted to a wall using suitable screws. Once mounted, the main unit can be slotted back into place and the screws tightened.



## Adjust your boiler settings

For complete control, it is important to ensure that it is the only LightwaveRF Boiler Switch that manages the on/off status of your boiler, and that it cannot be overridden by another thermostatic control or separate mode of operation.

If your boiler has an internal timer or clock, ensure that it is switched to 'Always ON' or, alternatively, disabled. If there is an internal thermostat for heating, make sure that this is set to 'Maximum'. Please refer to your specific boiler manual to see how this is done.



Set to 'always on' and disable the clock



Set to heating internal thermostat to max.



## Basic Operation

The Boiler Switch is designed to turn your boiler on and off. It is designed to be 'linked' to, and controlled by, the LightwaveRF Home Thermostat. The Boiler Switch will then automatically abide by the temperatures and schedules that you set from Thermostat. If the Home Thermostat is linked to the Lightwave Link, you will also be able to control and schedule your Boiler from your smartphone using the LightwaveRF App.

This section will show you how to setup the basic functions of the Boiler Switch. The following section will show you how to link the Boiler Switch to a Home Thermostat in order to integrate it into your heating system. **To achieve smartphone control of the Boiler, it must normally be linked to a LightwaveRF Home Thermostat which in turn must be linked to the Lightwave Link.**

### Understanding the Indicator LEDs

**Steady Green 'On':** The boiler is on

**Steady Red 'Off':** The boiler is off

**Alternate On/Off (longer on LED):** Linking mode

**Alternating Off/On (Longer off LED):** Unlinking mode

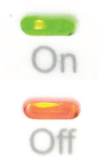

## The Standby button

If not connected to a Home Thermostat, pressing the Standby button on the Boiler Switch toggles the Boiler on and off. Once the Boiler Switch is linked to a Home Thermostat, pressing Standby will toggle between the set 'on' and 'setback' temperatures stipulated by this device (see Home Thermostat and App instructions to learn how to do this).

When connected to a Home Thermostat, if the heating is on, pressing the Standby button overrides the current schedule and turns **off** the heating (activates setback temperature) until the next scheduled 'on period'. If the heating is off, pressing the Standby button will turn the heating on (activates on temperature) until the next 'off period'.

Holding the Standby button for a couple of seconds activates 'Away mode'. Away mode also reverts to a pre-set setback temperature; however, rather than returning to the schedule at the next on/off period, the mode will continue to remain active until it is manually cancelled by pressing the Standby button. The Standby setback temperature and Away mode temperature is also stipulated by what is set on the Thermostat. These functions can also be carried out on the App.







## The Boost button

Pressing the Boost button on the Boiler Switch raises the target temperature several degrees above the current temperature for the duration of one hour. If the target temperature is already several degrees higher than the actual temperature, then pressing boost will simply match this temperature.

## Using the Heating Handset

A LightwaveRF Heating Handset can be linked to a Boiler Switch via a Home Thermostat.

Once linked, the Standby button on the Handset will toggle between Running and Standby modes in the same way as the Standby button on the Switch. The Boost button operates the Switch Boost button.

The plus and minus arrows on the handset will raise or lower the target temperature a few degrees above or below the current temperature.





### Linking the Boiler Switch to the Home Thermostat

In order to schedule your heating and to use the heating remotely, you will need to 'link' the Boiler Switch to the LightwaveRF Home Thermostat. The Boiler Switch can be linked to the Thermostat using the following method.

- 1.** Press and release the 'Link' button on the Boiler Switch (the on and off LEDs will flash alternately).
- 2.** Press and release the 'Link' button on the Home Thermostat. 'Link Ok' should appear on the display to indicate a successful link.

To unlink a Home Thermostat, press and release the Linking button on the Boiler Switch and then press the Standby button. This activates 'unlinking' mode. Press the Link button on the Thermostat. The 'deleted' should flash on the screen indicate that the devices have been unlinked.

To completely clear the memory of the Boiler Switch, press and release the Linking button. Then hold the Linking button until the LEDs flash rapidly. Finally, press and release the Linking button once more. The Off LED should flash.



# Add other Heating Devices



**Home Thermostat**  
(monitors house temp.)



**Boiler Switch**  
(turns boiler on/off)



**Lightwave App**  
(control any room from anywhere)



**Heating Remote**  
(sets house temp.)



**Lightwave link**  
(runs the show)

Lounge

**Room Thermostat**  
(controls several TRVs)



Bedroom 1



**TRV**  
(controls radiator)

Bedroom 2



**Window Trigger**  
(open window turns off TRV)

**Room by room radiator control**



# Heating Scenarios



## 1. (Intermediate): Remote control of the Boiler

**Required: Boiler Switch, Home Thermostat, Heating Remote**

It is really comfortable and convenient to be able to have direct control over the house temperature without having to get up and alter the thermostat or boiler. This can be achieved using the LightwaveRF Home Thermostat, Boiler Switch and Heating Remote. You can turn the temperature up and down, boost the heating for an hour or simply turn it on/off. Use the Remote to control the Home Thermostat from the comfort of the sofa, and this will, in turn, relay the commands to the Boiler Switch.



## 2. (Advanced): Zoned Heating

Required: TRVs, Lightwave Link, Boiler Switch, Thermostat etc.

With the LightwaveRF App and the **Lightwave Link** you can create an expandable zoned system that can take care of your entire home. Temperatures can be set for each room or 'heating zone', and heating can be planned week by week and room by room. If you have electric radiators, you can still achieve this by connecting them to Electric Switches. You can also link wet radiators, using TRVs, AND electric radiators and schedule them together for a totally integrated heating system!





**Q. Does the Boiler Radiator Switch have a 'standby' power consumption**

**A.** The Switch has a standby power consumption of approx. 0.5W. This is because the in-built radio receiver requires power in order to receive commands. This rate is low & well within government energy guidelines.

**Q. Does the Boiler Switch have to work with a Home Thermostat?**

**A.** Yes. The Boiler Switch must link to a Home Thermostat to operate.

**Q. Is it legal for me to install a LightwaveRF Boiler Switch myself?**

**A.** Yes, LightwaveRF products are fully legal to install in your own home.

**Q. Is it possible to overload the Switch?**

**A.** 7A max. loading applies and should not be exceeded.

**Q. Can I link more than one Boiler Switch to a Thermostat?**

**A.** No. The Boiler Switch is designed to be controlled by a single thermostat, and each Home Thermostat is only capable of being linked to one Boiler Switch. More than one Boiler Switch can be controlled on the App (e.g. in a multi-zone system), however, each one must have an accompanying Thermostat.

**Q. Can I use the Boiler Switch to control Hot Water?**

**A.** We recommend using the LightwaveRF Electric Switch to control your hot water system.



## Specification

**RF frequency:** 868 MHz

**Input:** 230V

**Rating:** 7 Amps

**Warranty:** 2 year standard warranty

Lightw<sup>w</sup>ave<sup>RF</sup>

**MEGAMAN<sup>®</sup>**

2 Quadrant Park  
Mundells  
Welwyn Garden City  
Herts  
AL7 1FS  
01707 386035

[www.lightwaverf.house](http://www.lightwaverf.house)